

Customer Value through Innovation



Float Valves

Jobe MegaFlow Trough Valve



Jobe Megaflow Trough Valve

Megaflow Trough Valves function by operating a small pilot valve which in turn operates the main diaphragm valve. They are a good choice where their high flow, compact, robust and non corrosive construction are required for a high level of adaptability. The valve is configured for bottom or side underwater mounting only. This underwater installation helps to avoid the issue of freezing.

The valve operates under a varying water level differential that is dependent on the pressure in the system. Due to this water level differential it will limit the pump cycles and prolong the life of the pump. The valve is UV stabilised so it will continue to perform, even in harsh sunlight conditions. The armless design reduces the possibility of stock damage when compared with conventional brass arm valves.



Innovative Design

- Armless design reduces possibility of stock damage.

Non-Corrosive

- Constructed from corrosion resistant materials.

Vast Applications

- Can be bottom, side or top mounted.

Economical

- 20-60mm water level differential reduces the pump cycles.

Durable

- Under water installation helps avoid freezing.

Specifications

- Pressure range: 30-700 kPa.
- Maximum temperature: 60°C.

Installation

- Sealing threads should be joined with Teflon thread tape or an appropriate sealing compound.



Parts & Materials

Parts & Materials					
Body	Glass-filled Nylon	Diaphragm	EPDM	O-Rings	Nitrile
Yellow & White Internal Parts	Acetyl	Springs, Bolts, Nuts, Pin & Screws	304 Stainless Steel	Float	HDPE
Filter	Polyethylene / Nylon	Seal	Urethane	Float Cord	Polyester
Actuator Cap	ABS	Detach Locking Ring	Acetyl	Seal Washer	LDPE

Dimensions

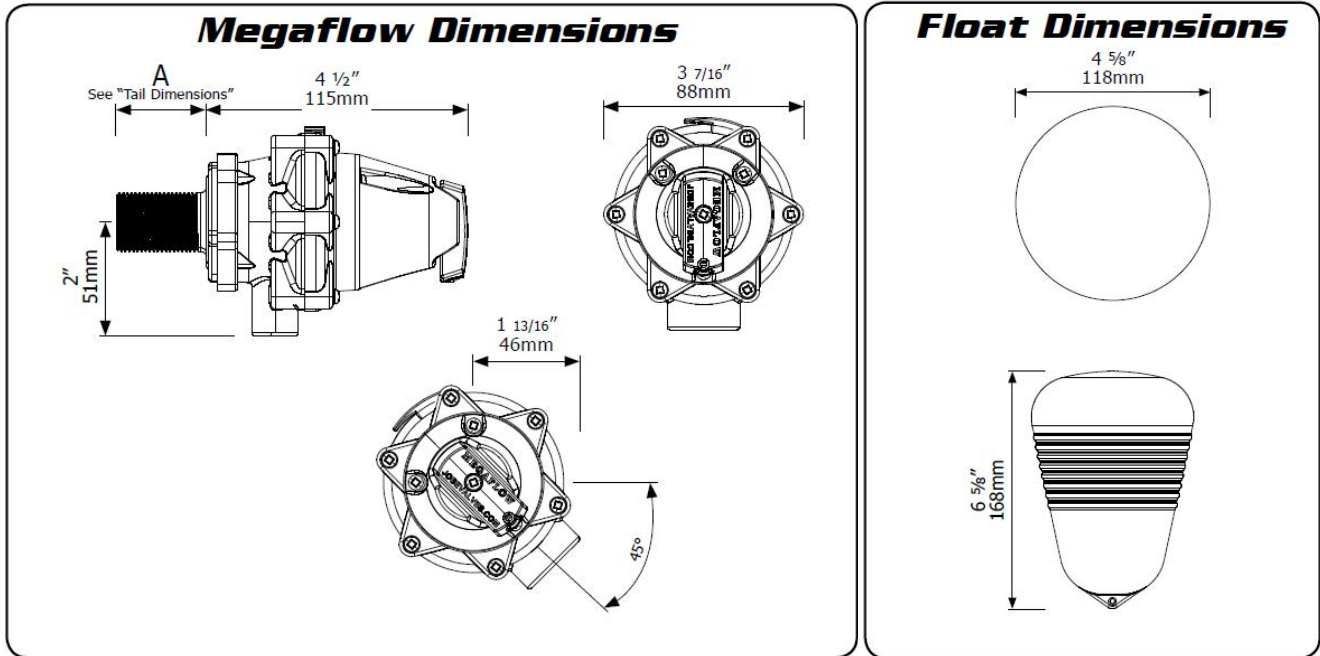

Range

Jobe Megaflow Trough Valve



PART NUMBER	ITEM NUMBER	BASE	SIZE	THREAD
MFV15DLT	08372303000	DETACH	15MM (1/2")	LONG
MFV20D	08372303005	DETACH	20MM (3/4")	
MFV20DLT	08372303015	DETACH	20MM (3/4")	LONG
MFV25D	08372303020	DETACH	25MM (1")	
MFV25DLT	08372303025	DETACH	25MM (1")	LONG
MFV32D	08372303030	DETACH	32MM (1 1/4")	
MFV32DLT	08372303035	DETACH	32MM (1 1/4")	LONG

*A comprehensive list of spare parts for the Topaz Megaflow Valve is available, please contact your local Area Sales Manager or our Customer Service Team for details.

Customer Value through Innovation



NORMA Pacific Australia

74 Bazalgette Crescent
Dandenong South VIC 3175

Tel: 1300 252 677
Fax: 03 9761 4030

www.normagroup.com.au
sales.au@normagroup.com.au